

# Proton300k™ Computer Platform

## Radiation Hardened Computer Platform with Reconfigurable FPGAs

The Proton300k™ computer platform is a high performance radiation hardened processing solution that meets the challenges of the harsh space environment. Several advanced technologies are brought together in the Proton300k™ to provide industry leading performance, power, and radiation hardening. The Proton300k™ computer platform can accept several reconfigurable FPGAs to accommodate a wide variety of space applications.

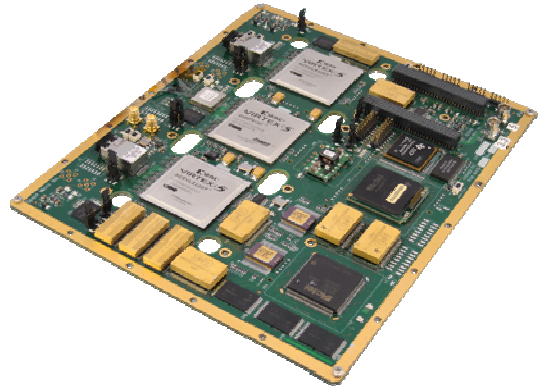

### Need

Commercial digital signal processors (DSPs) and FPGAs suffer from radiation effects in the space environment, particularly single event upsets (SEU) and single event functional interrupts (SEFI). Furthermore, traditional radiation hardened computer suppliers have struggled to deliver performance and user-programmability while maintaining radiation hardness. The Proton300K™ utilizes Space Micro's patent-pending Time-Triple Modular Redundancy (TTMR™) and Hardened Core (H-Core™) technologies to solve the SEU and SEFI issues commonly encountered with DSPs and FPGAs.

### Highlights

In addition to its radiation hardening, the Proton300k™ has a modular architecture, so that it can accommodate a number of FPGAs as well as various memory and communication bus options. Its low power requirements also make it ideal for a wide variety of space applications.

SEU mitigation is handled with the on-board DSP. This mitigation can be turned on or off. This allows the utilization of the full power of the FPGAs during non-critical aspects of the mission, while mitigating SEUs during critical phases.

### Applicability

With the capability to accept several reconfigurable FPGAs, the Proton300k™ can be customized to accommodate the needs of a variety of satellite and launch systems. This includes processing of image and sensor data, advanced algorithms, or many other applications in LEO or GEO orbits.

### Key Features

- Reconfigurable number of FPGAs
- Radiation hardened on demand
- Low power requirements
- High performance
- Modular bus and communications options
- User programmable

10237 Flanders Court  
San Diego, CA 92121

Phone: (858) 332-0700

Fax: (858) 332-0709

[www.spacemicro.com](http://www.spacemicro.com)

Page 1



# Proton300k™ Computer Platform

## Technical Specifications

### Radiation Tolerance

- **TID:** > 100krad (Si)
- **SEFI:** 100% recoverable
- **SEU:** < 1.0E-4 unrecoverable errors per day
- **SEL:** Immunity at >70 LET (MeV-cm<sup>2</sup>/mg)

### Fixed Point Digital Signal Processor

- Texas Instruments TMS320C6415
- Handles voting for SEU mitigation via TTMR™
- Advanced Very Long Instruction Word (VLIW) DSP core
- 128 Kbit L1 program cache
- 128 Kbit L1 data cache
- 8 Mbit L2 SRAM with flexible allocation
- 32-bit fixed point with 8,000 MIPS performance
- Three 32-bit general purpose timers

### Field Programmable Gate Arrays (FPGAs)

- Xilinx Virtex-5 FXT
- Up to four on each board, depending on configuration
- Advanced serial connectivity
- RocketIO GTX transceivers
- SelectIO technology
- Powerful clock management tile clocking
- 65 nm copper CMOS process technology

### Memory

- 64 to 512 MB SDRAM with EDAC
- Option for 1-8 MB EEPROM
- Option for 512 MB-1GB radiation hardened flash memory

### Form Factors

- cPCI 3U (100x160mm, 3.94x6.3")
- cPCI 6U (230x160mm, 9.2x6.3")
- PCI-104S (90x127mm, 3.55x5")
- Custom size available
- Size depends on required FPGA capacity

### I/O Options

- 32-bit, 33 MHz PCI internal and external bus
- 230 Kbps UART with RS422
- Two inter-integrated circuit (IIC) buses, multi-master & slave interfaces
- Three multi-channel buffered serial ports (SPI)
- 16 programmable general purpose I/O pins
  - **Options Include:**
    - LVDS
    - 1553
    - SpaceWire
    - CAN
    - Ethernet
    - USB
    - I2C
    - PCI Express

Weight	Depends on form factor, configuration and FPGA requirements
Operating Temperature	-40°C to 90°C, option for MIL-STD temperature range
Power	≈ 5-7 W for DSP, FPGA is dependent on configuration
Interfaces	All popular I/O's supported through bus structure

# Proton300k™ Computer Platform

## Innovations and Enabling Technologies

Standard commercial processors are not suitable for space applications because they are prone to single event effects (SEEs) caused by radiation in the harsh space environment. These include single event upsets (SEUs), which will cause data errors, as well as functional interrupts (SEFIs), which could completely lock up the processors. Space Micro has developed technologies to mitigate, detect, and correct these radiation effects for processors in harsh space environments.

### TTMR™

Time Triple Modular Redundancy (TTMR™) detects and corrects SEUs, thereby enabling the use of state-of-the-art commercial processors. TTMR™ combines time with triple modular redundancy (TMR). The addition of time takes advantage of very long instruction word (VLIW) processors for parallel processing of instructions. TMR uses separate arithmetic logic units (ALUs) within a single DSP to correct any SEU. TTMR™ implementation is transparent to DSP users from a hardware and software standpoint.

TTMR™ can be turned on or off at any time during a mission. During the most critical parts of the mission, where data errors are unacceptable, TTMR™ is turned on to mitigate SEUs. TTMR™ can be turned off during less critical parts of the mission in order to utilize the full power of the FPGAs.

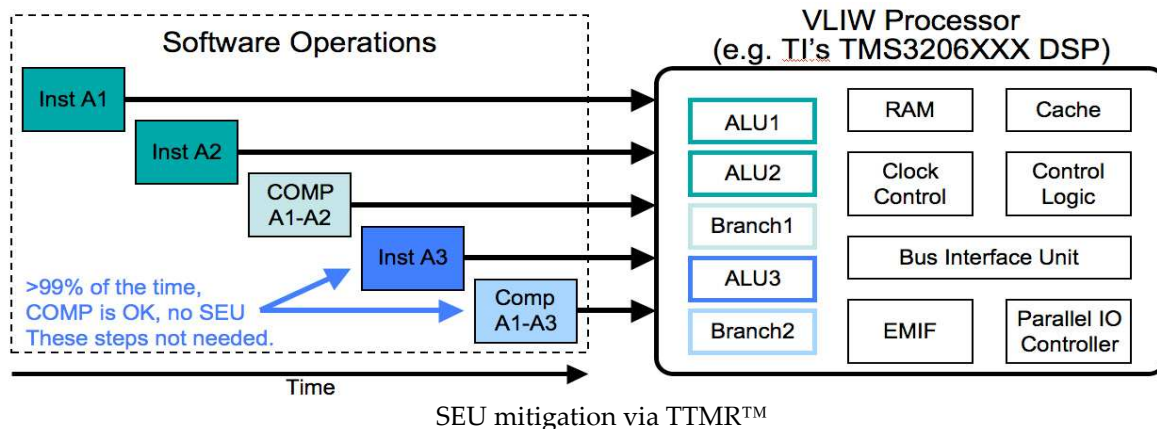

### H-CORE™

Space Micro's Hardened Core (H-Core™) technology monitors processor functionality in real-time and detects and corrects any SEFIs that occur. Through a combination of hardware and software techniques, H-Core™ monitors signals and initiates post-SEFI recovery interrupts or a full reset as required.

H-Core™ technology can be in the form of a discrete IC, or it can be embedded into the FPGA glue logic. Both methods preserve the SEFI immunity for the Proton300k™ that H-Core™ provides.

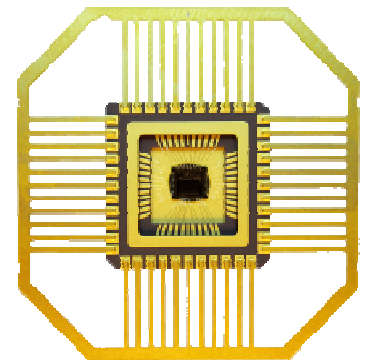

H-Core™ radiation hardened IC

10237 Flanders Court  
San Diego, CA 92121

Phone: (858) 332-0700

Fax: (858) 332-0709

[www.spacemicro.com](http://www.spacemicro.com)

Page 3



# Proton300k™ Computer Platform

## Overview

The Proton300k™ provides an advanced, reconfigurable, radiation hardened computer platform that is the ideal solution for a wide range of space applications, including advanced image processing. The Proton300k™ utilizes Space Micro's radiation hardening technology to provide industry leading performance and a power computer platform that mitigates SEEs during critical phases of a mission. Its modularity allows for multiple FPGAs as well as various memory and communication bus options. The Proton300k™ platform provides the first high-speed, SEU-hardened computing solution with reconfigurable FPGAs on-board for space applications.

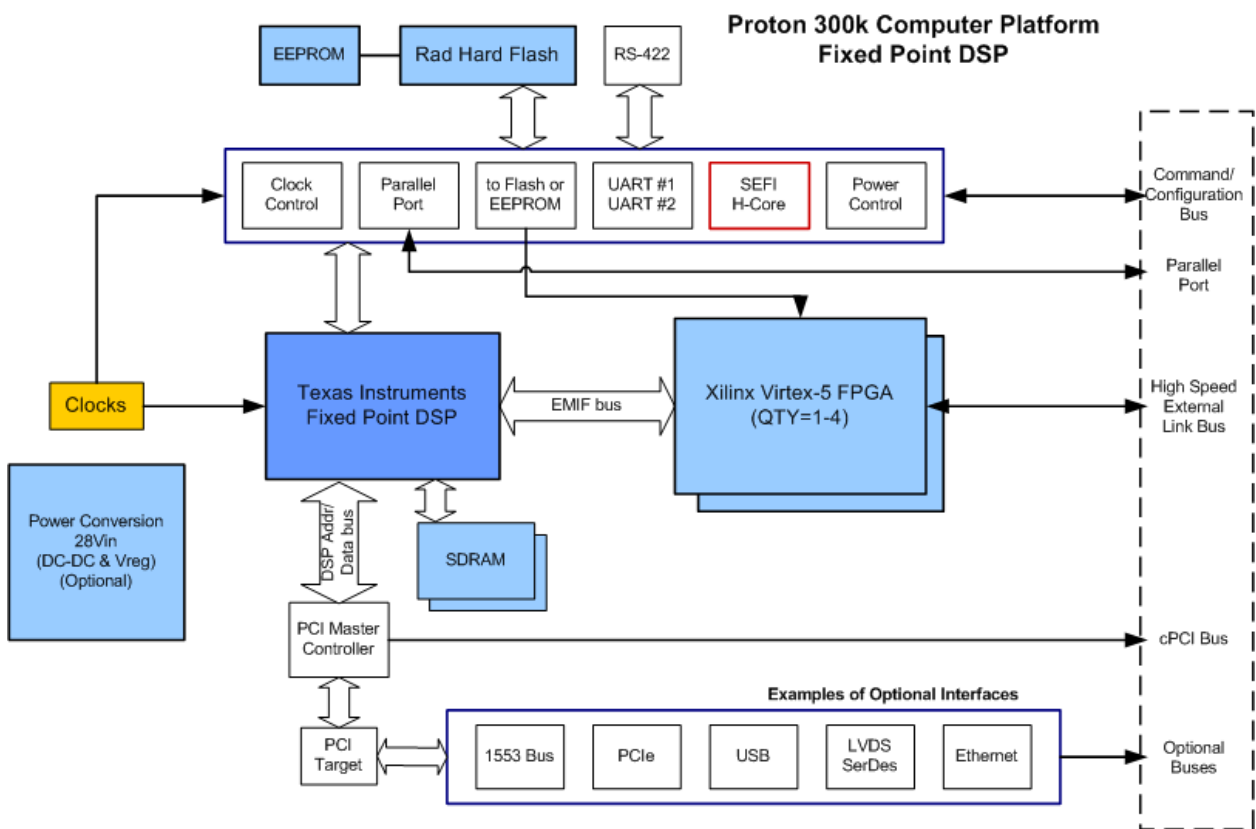

Proton300k Block Diagram

Contact Space Micro for complete systems characteristics, specific configurations, and availability of the Proton300k™.